



DEPARTMENT OF REGULATORY AND ECONOMIC RESOURCES (RER)
 BOARD AND CODE ADMINISTRATION DIVISION
NOTICE OF ACCEPTANCE (NOA)

MIAMI-DADE COUNTY
 PRODUCT CONTROL SECTION
 11805 SW 26 Street, Room 208
 Miami, Florida 33175-2474
 T (786) 315-2590 F (786) 315-2599
www.miamidade.gov/economy

BASF Corporation (FL)
3550 St. Johns Bluff Rd. South
Jacksonville, FL 32224

SCOPE:

This NOA is being issued under the applicable rules and regulations governing the use of construction materials. The documentation submitted has been reviewed and accepted by Miami-Dade County RER-Product Control Section to be used in Miami Dade County and other areas where allowed by the Authority Having Jurisdiction (AHJ).

This NOA shall not be valid after the expiration date stated below. The Miami-Dade County Product Control Section (In Miami Dade County) and/or the AHJ (in areas other than Miami Dade County) reserve the right to have this product or material tested for quality assurance purposes. If this product or material fails to perform in the accepted manner, the manufacturer will incur the expense of such testing and the AHJ may immediately revoke, modify, or suspend the use of such product or material within their jurisdiction. RER reserves the right to revoke this acceptance, if it is determined by Miami-Dade County Product Control Section that this product or material fails to meet the requirements of the applicable building code.

This product is approved as described herein, and has been designed to comply with the Florida Building Code, including the High Velocity Hurricane Zone.

DESCRIPTION: Senergy Senerflex EIF System over CMU Substrate – L.M.I.

APPROVAL DOCUMENT: Drawing titled "Senergy Assembly Detail for Senerflex Wall System over CMU Substrate", sheets 1 through 3 of 3, dated 06/11/2013, prepared by BASF Corporation, signed and sealed by William O. Bishop, P.E., bearing the Miami-Dade County Product Control renewal stamp with the Notice of Acceptance number and expiration date by the Miami-Dade County Product Control Section.

MISSILE IMPACT RATING: Large and Small Missile Impact Resistant

LABELING: Each unit shall bear a permanent label with the manufacturer's name or logo, city, state and following statement: "Miami-Dade County Product Control Approved", unless otherwise noted herein. Each container (bucket or drum) needs to be labeled. Unit is further defined as each roll of reinforcing mesh.

RENEWAL of this NOA shall be considered after a renewal application has been filed and there has been no change in the applicable building code negatively affecting the performance of this product.

TERMINATION of this NOA will occur after the expiration date or if there has been a revision or change in the materials, use, and/or manufacture of the product or process. Misuse of this NOA as an endorsement of any product, for sales, advertising or any other purposes shall automatically terminate this NOA. Failure to comply with any section of this NOA shall be cause for termination and removal of NOA.

ADVERTISEMENT: The NOA number preceded by the words Miami-Dade County, Florida, and followed by the expiration date may be displayed in advertising literature. If any portion of the NOA is displayed, then it shall be done in its entirety.

INSPECTION: A copy of this entire NOA shall be provided to the user by the manufacturer or its distributors and shall be available for inspection at the job site at the request of the Building Official.

This NOA renews NOA # 08-0807.14 and consists of this page 1 and evidence page E-1, as well as approval document mentioned above.

The submitted documentation was reviewed by Carlos M. Utrera, P.E.



[Signature]
 09/20/2013

NOA No. 13-0717.02
 Expiration Date: September 25, 2018
 Approval Date: September 26, 2013
 Page 1

NOTICE OF ACCEPTANCE: EVIDENCE SUBMITTED

A. DRAWINGS

1. Drawing titled "Senergy Assembly Detail for Senerflex Wall System over CMU Substrate", sheets 1 through 3 of 3, dated 06/11/2013, prepared by BASF Corporation, signed and sealed by William O. Bishop, P.E.

B. TESTS "Submitted under NOA # 08-0807.14"

1. Test reports on 1) Air Infiltration Test, per FBC, TAS 202-94
2) Uniform Static Air Pressure Test, Loading per FBC TAS 202-94
3) Water Resistance Test, per FBC, TAS 202-94
4) Cyclic Wind Pressure Loading per FBC, TAS 203-94
along with marked-up drawings and installation diagram of Senergy Senerflex Classic PB over CMU Wall (EIFS) System, prepared by Hurricane Test Laboratory, LLC, Test Report No. **0469-0907-07**, dated 06/30/2008, signed and sealed by Vinu J. Abraham, P.E.

C. CALCULATIONS

1. None.

D. QUALITY ASSURANCE

1. Miami-Dade Department of Regulatory and Economic Resources (RER)

E. MATERIAL CERTIFICATIONS

1. None.

F. STATEMENTS

1. Drawing statement of code conformance to 2010 FBC prepared by BASF Corporation, 06/11/2013, signed and sealed by William O. Bishop, P.E.

"Submitted under NOA # 08-0807.14"

2. Laboratory compliance letter for Test Report No. **0469-0907-07**, issued by Hurricane Test Laboratory, LLC, dated 06/30/2008, signed and sealed by Vinu J. Abraham, P.E.

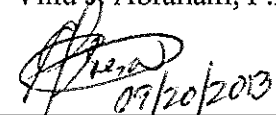

Carlos M. Utrera, P.E.
Product Control Examiner
NOA No. 13-0717.02

Expiration Date: September 25, 2018
Approval Date: September 26, 2013

Assembly Detail for Senerflex Wall System over CMU Substrate

REVISIONS	DATES
FBC Version	6-11-2013

FLORIDA P.E.: William O. Bishop, P.E.
REGISTRATION NO.: 63305

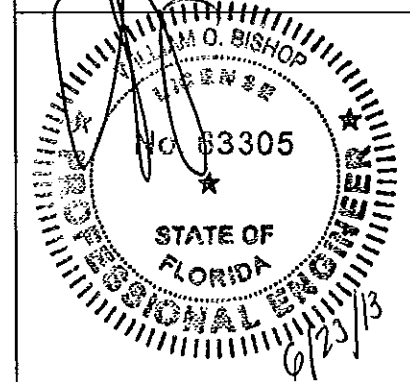

FOR OFFICE USE

PRODUCT RENEWED
as complying with the Florida
Building Code
Acceptance No 13-0717.02
Expiration Date 07/25/2018
By *[Signature]*
Miami/Dade Product Control

BASF Corporation
3550 St Johns Bluff Rd South
Jacksonville, FL 32224
800-221-9255

APPLICATION NOTES

- 1) SENERFLEX BASE COAT IS MIXED AT TIME OF USE WITH PORTLAND CEMENT (1 TO 1 BY WEIGHT) AND WATER WITH PADDLE AND DRILL TO A HOMOGENEOUS CONSISTENCY.
- 2) SENERFLEX BASE COAT IS APPLIED TO THE BACK OF THE EPS INSULATION BOARD USING A 3/8" X 3/8" U NOTCHED TROWEL HAVING 3/8" FLAT SEGMENTS BETWEEN NOTCHES.
- 3) MIAMI-DADE COUNTY APPROVED EPS INSULATION HAS A DENSITY OF 1 PCF AND IT SHALL BE APPLIED HORIZONTALLY IN A RUNNING BOND PATTERN STAGGERING VERTICAL JOINTS AND CORNERS.
- 4) AFTER BASE COAT IS DRIED AND INSULATION BOARD IS RASPED TO A SMOOTH SURFACE, A LAYER OF SENERFLEX BASE COAT IS APPLIED TO THE EXPOSED SURFACE. FLEXGUARD 4 REINFORCING MESH IS EMBEDDED IN THE WET BASE COAT BY TROWELING FROM THE CENTER OUT. ALL EDGES ARE LAPPED 2 1/2 INCHES.
- 5) SENERGY FINISH IS AN ACRYLIC BASED TEXTURED EXTERIOR COATING READY MIXED FROM THE FACTORY. IT IS APPLIED WITH A STAINLESS STEEL TROWEL AND FLOATED TO A DESIRED TEXTURE.

GENERAL NOTES

- 1) THIS SYSTEM HAS BEEN DESIGNED IN ACCORDANCE WITH THE FLORIDA BUILDING CODE 2010 EDITION AND ITS LATEST SUPPLEMENTS.
- 2) THIS SYSTEM HAS BEEN TESTED IN ACCORDANCE WITH MIAMI-DADE COUNTY PROTOCOL TAS-202 & TAS-203 FOR STRUCTURAL AND CYCLIC TESTING.
- 3) THIS SYSTEM SHALL BE APPLIED BY A LICENSED PLASTERING CONTRACTOR FOLLOWING THIS NOTICE OF ACCEPTANCE, THE RECOMMENDATIONS OF SENERGY AND THE APPLICABLE SECTION OF THE FLORIDA BUILDING CODE.
- 4) THE ENGINEER AND/OR ARCHITECT OF RECORD FOR EACH PROJECT USING THIS SYSTEM SHALL DESIGN THE MASONRY WALL AS REQUIRED BY GOVERNING CODE AND THIS DOCUMENT.
- 5) DETAILS ON SHEET 2 & 3 OF 3 ARE TYPICAL AND SHOW INTENT TO PREVENT WATER INFILTRATION INTO AND BEHIND THE SYSTEM. ALTERNATE DETAILS AND SPECIFIC CONDITIONS NOT COVERED BY THE TYPICAL DETAILS ARE THE RESPONSIBILITY OF THE LICENSED DESIGN PROFESSIONAL IN CONSULTATION WITH SENERGY.

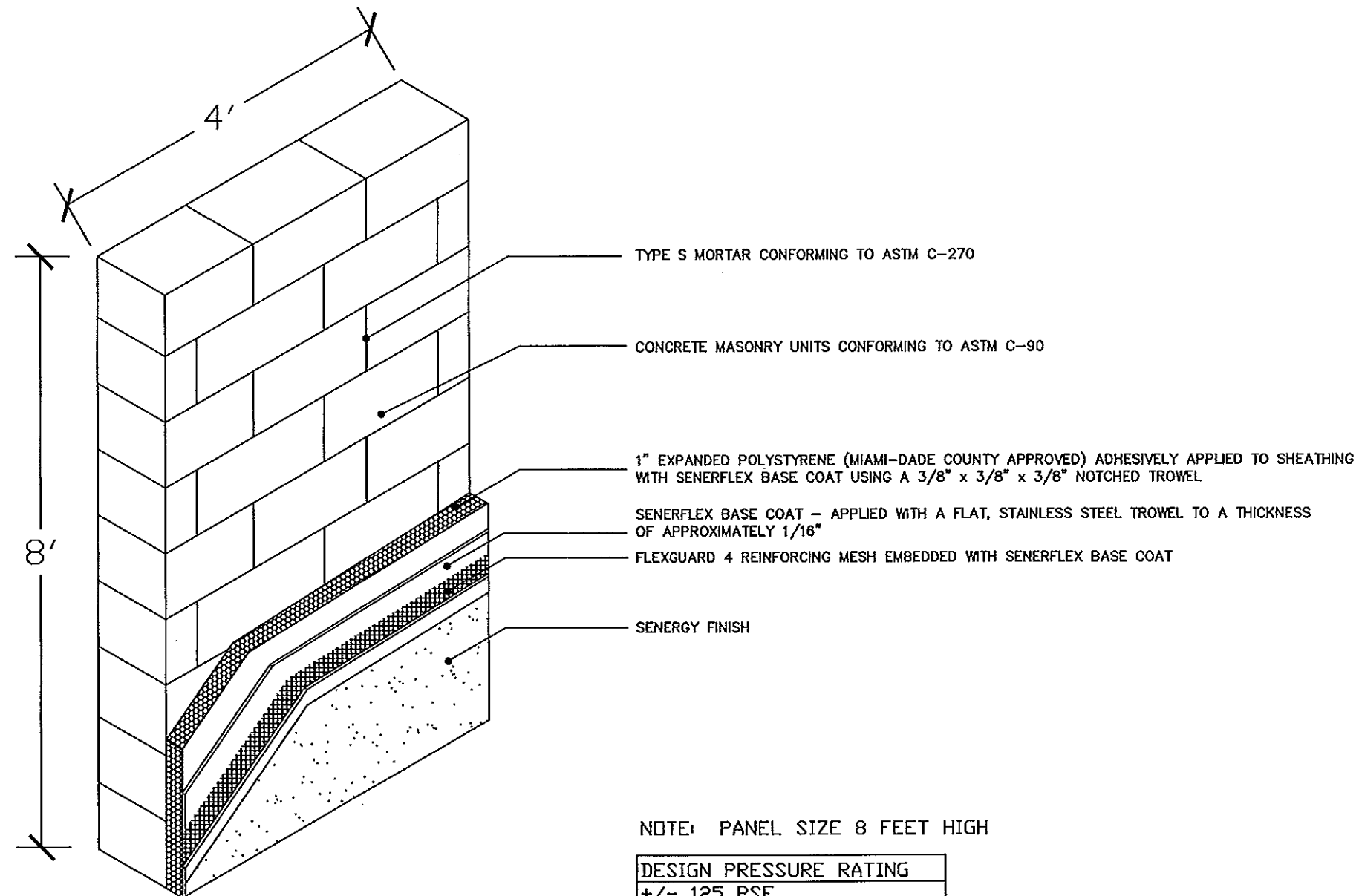

NOTE: PANEL SIZE 8 FEET HIGH

DESIGN PRESSURE RATING
+/- 125 PSF
INSTALLED OVER AN IMPACT RESISTANT SUBSTRATE

Typical Details for Senerflex Wall System over Impact Resistant Substrate (CMU)

REVISIONS	DATES

FLORIDA P.E.: William O. Bishop, P.E.
REGISTRATION NO.: 63305

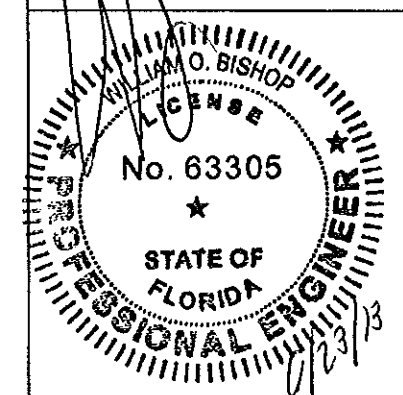

FOR OFFICE USE

PRODUCT RENEWED
as complying with the Florida
Building Code
Acceptance No 13-0717.02
Expiration Date 09/25/2018
By *[Signature]*
Miami Dade Product Control

BASF Corporation
3550 St Johns Bluff Rd South
Jacksonville, FL 32224
800-221-9255

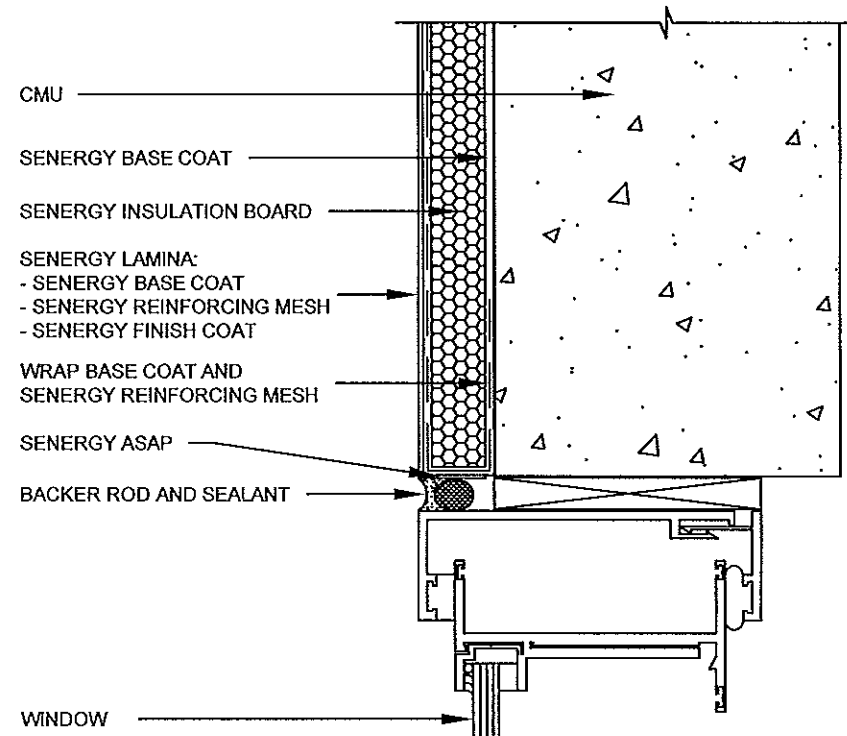

TYPICAL WINDOW HEAD (FLUSH)

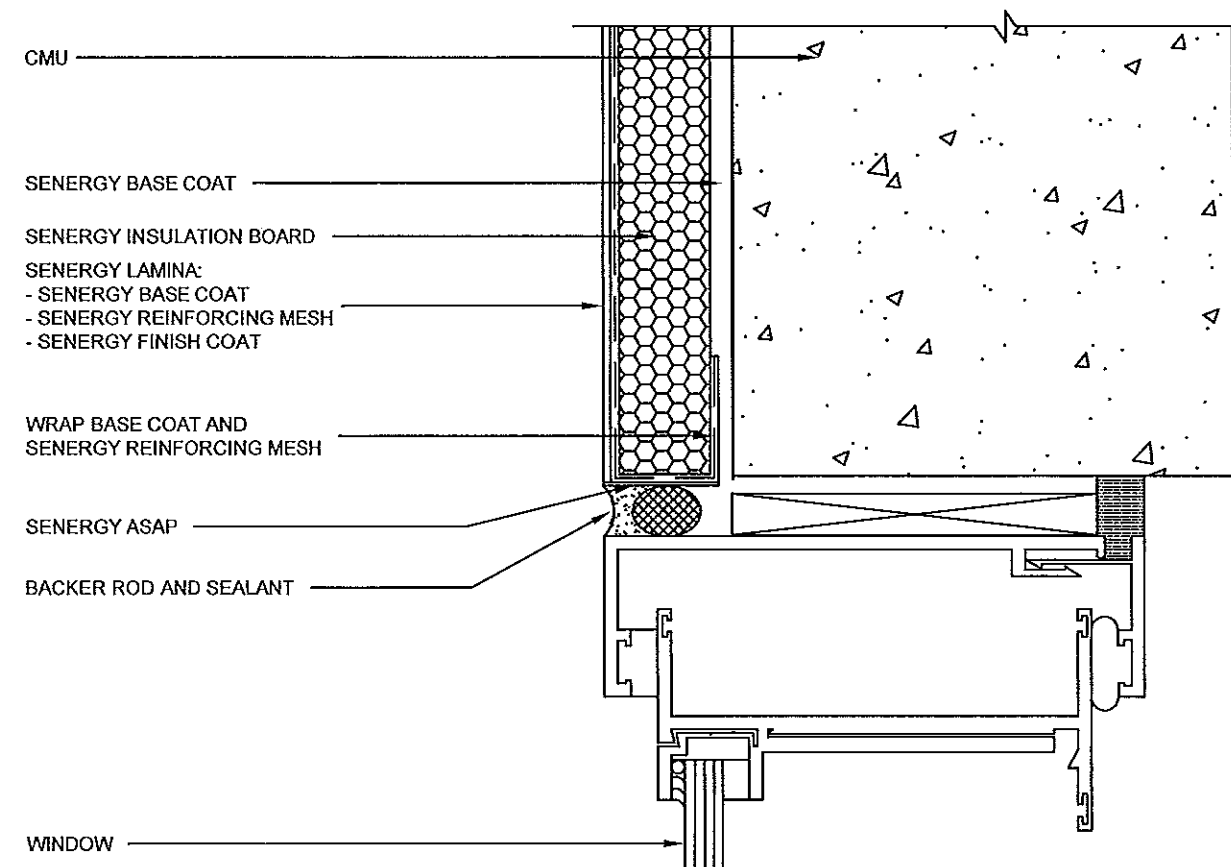

TYPICAL WINDOW JAMB (FLUSH)

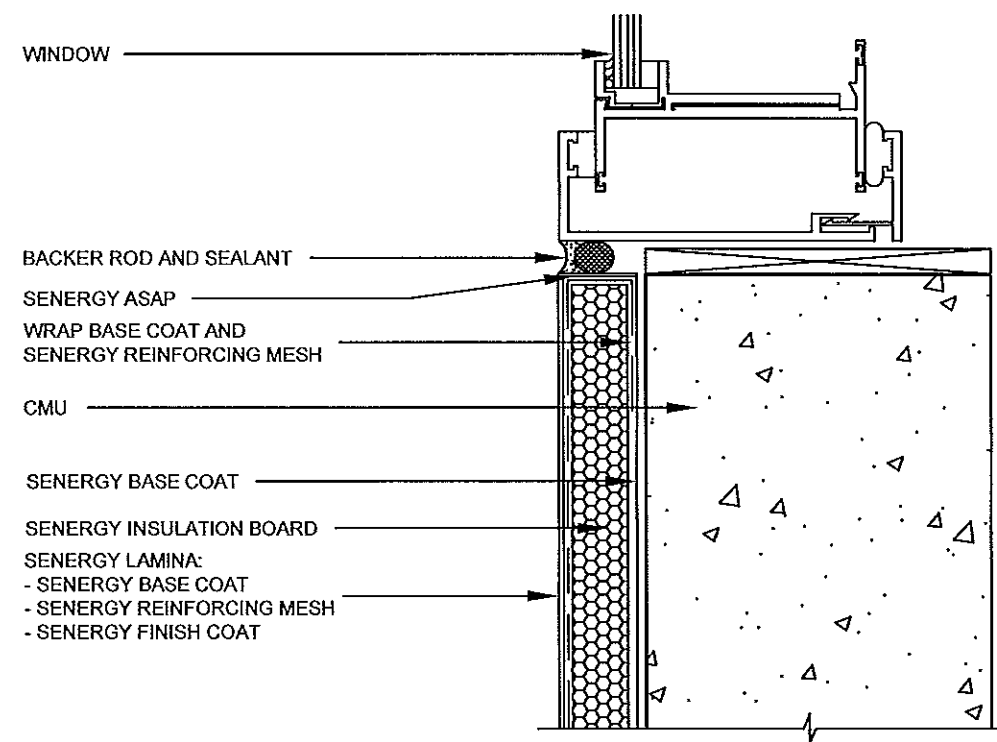

TYPICAL WINDOW SILL FLUSH

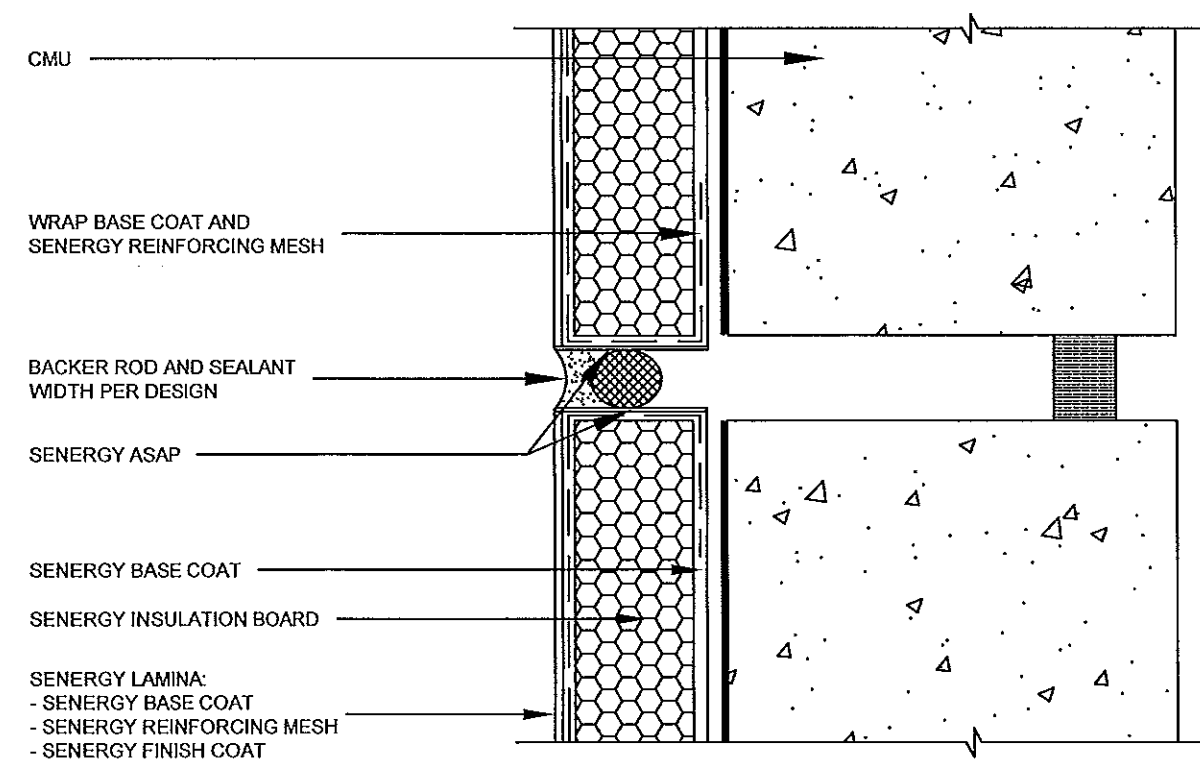

TYPICAL EXPANSION JOINT

Typical Details for Senerflex Wall System over Impact Resistant Substrate (CMU)

REVISIONS	DATES

FLORIDA P.E.: William O. Bishop, P.E.
REGISTRATION NO.: 63305

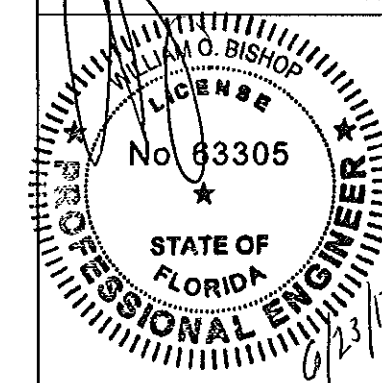

FOR OFFICE USE

PRODUCT RENEWED
as complying with the Florida Building Code
Acceptance No 13-0717.02
Expiration Date 09/25/2018
By *[Signature]*
Miami Date Product Control

BASF Corporation
3550 St Johns Bluff Rd South
Jacksonville, FL 32224
800-221-9255

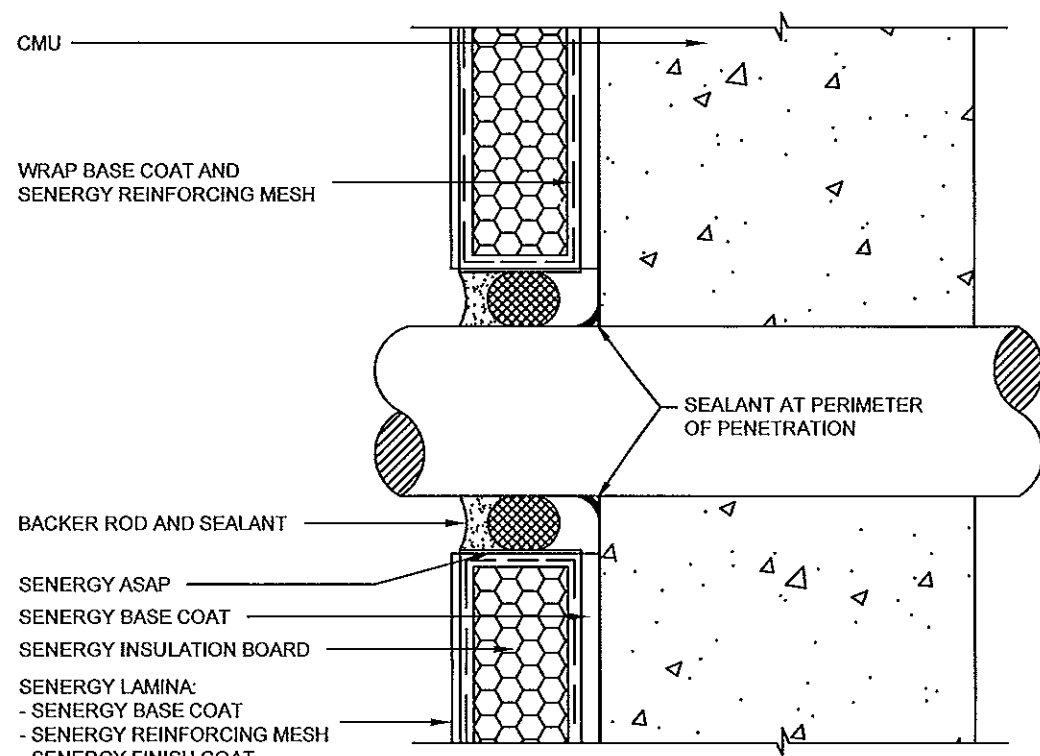

TYPICAL PIPE PENETRATION

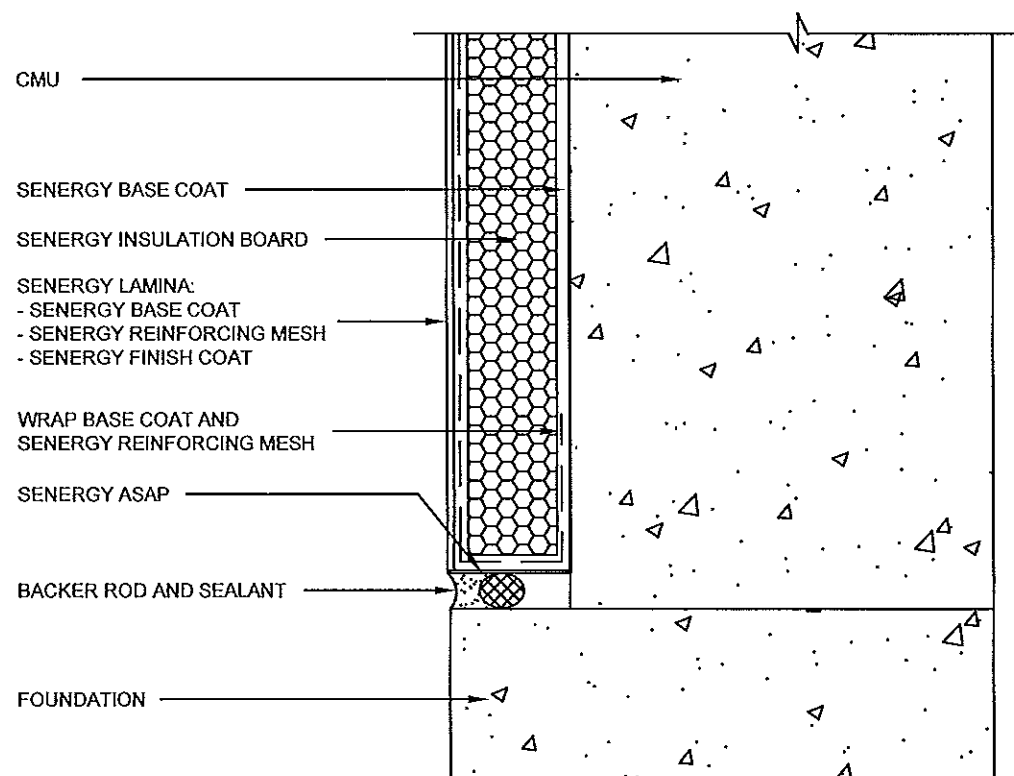

TYPICAL TERMINATION AT FOUNDATION (FLUSH)

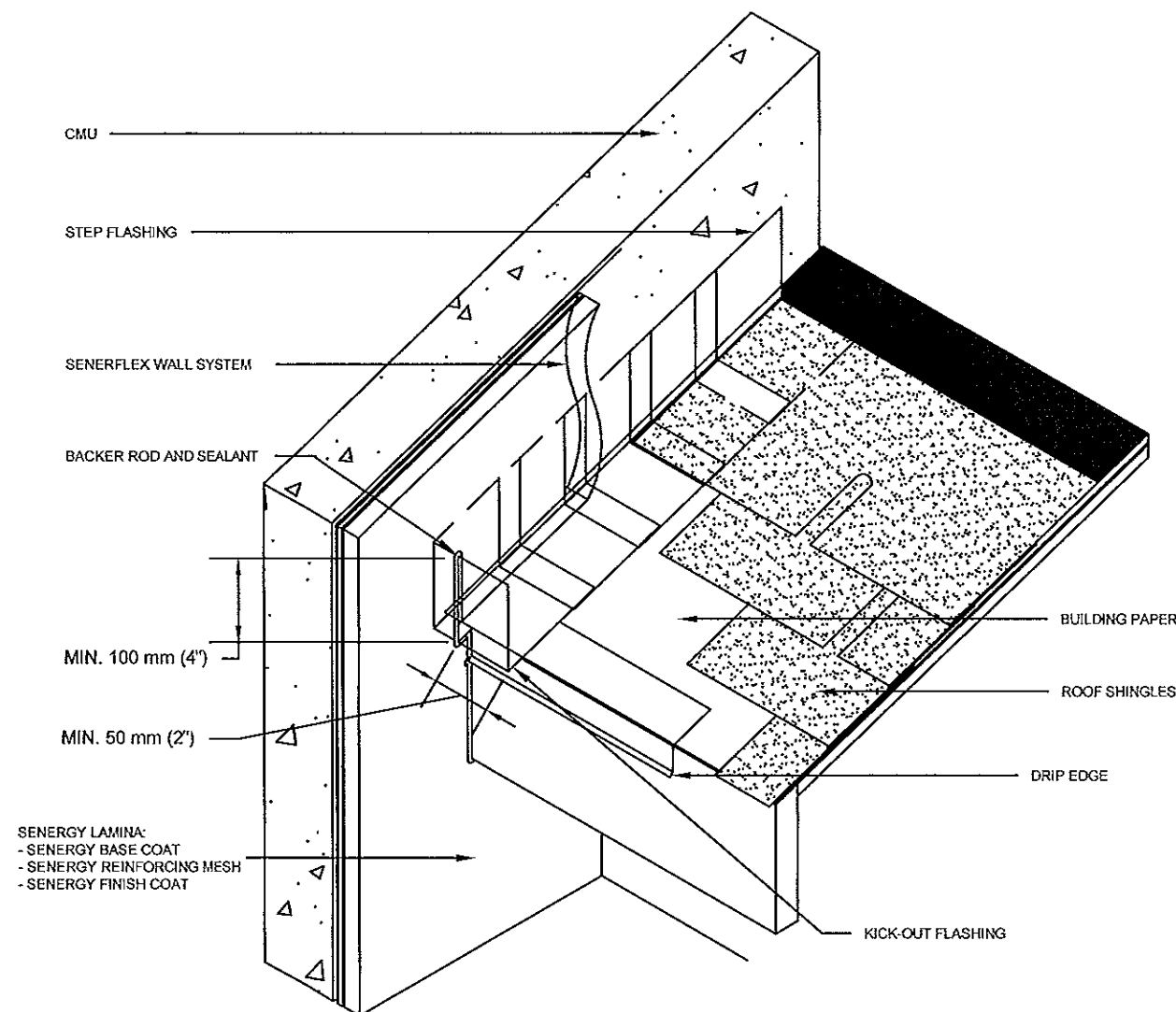

NOTE:
- KICK-OUT FLASHING MUST BE ANGLED 100° MIN. TO ALLOW FOR PROPER DRAINAGE.
- KICK-OUT FLASHING SEAMS MUST BE SOLDERED OR SEALED WITH APPROPRIATE SEALANT.
- TERMINATE SENERFLEX WALL SYSTEM MIN. 50 mm (2") ABOVE ROOF.

TYPICAL KICKOUT FLASHING DETAIL